

AB Fence Tech Sheet

Structural System Testing Conducted On AB Fence Panel Bond Beam

The following tech sheet summarizes a structural test performed on two precast AB Fence Panel Bond Beam. This summary provides information on test procedures and results.

Test Objective

The test was designed to evaluate current design methodologies and to validate the specific design moments used in our current design calculations. By precasting a bond beam and setting it on its side in a simply supported fashion we were able to determine an actual moment capacity for a typical Allan Block Fence bond beam.

Test Setup

The test started with the casting of two bond beam assemblies, one 7 panel block long with a sand grout mix and the other a 9 panel block long with a 3000 psi (21MPa) pea gravel concrete mix, both with number 4 rebar for horizontal reinforcement and #9 gage wire stirrups in every other core for vertical reinforcement, typical bond beam construction shown in Figure 1. Both bond beam assemblies were cast on a level steel jig. The grout was placed with an electric vibrating stinger to help consolidate the grout throughout the bond beam. The two different grout mixes were used to build a comparison between their reinforcement coverage ability. The bond beam with the sand mix flowed easily and provided superior bar coverage then the bond beam with the pea gravel concrete mix.

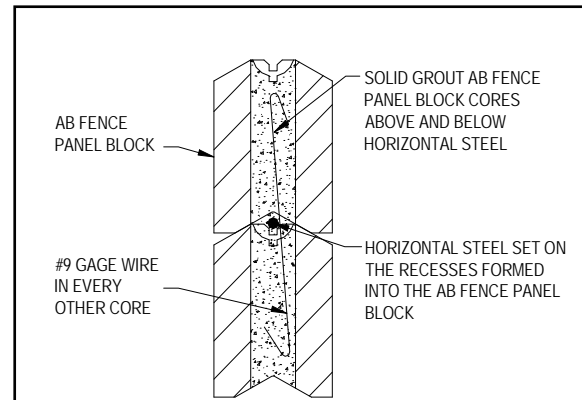

Figure 1: Typical Bond Beam Section

Test Procedure

Once the bond beam was placed and simply supported at the ends, an initial deflection was recorded and the loading process began. The dead weight was provided by individual panel block (47 lbs (21.3kg) each) placed side-by-side and on top of each other at the mid-span of the specimen. Figure 2 shows the bond beam supporting 26 panel block weighing approximately 1,222 lbs (554 kg) pounds with a deflection of 2 5/8" (67mm).



Figure 2: Loaded 7 Panel Bond Beam



allanblock.com

AB Fence Tech Sheet

Tech Sheet #2002

Structural System Testing Conducted On AB Fence Panel Bond Beam

Using simple beam bending formulas and recording the actual deflections, we were able to calculate the actual induced moments. As expected, the recorded deflections grew as the dead load increased. The bond beam failed at a 28 panel block dead load, which equates to an approximate 3870 ft-lbs (5249 N-m) of moment capacity. During the loading process the propagation of tension cracks appeared at mid-span, which show that the composite bond beam was acting as a monolithic unit and not as individual stacked parts. They were working together to resist the applied load.

Test Findings

Seven Panel Bond Beam

The specimen achieved an ultimate moment of 3,651 ft-lbs (4952 N-m). Comparing this to an actual fence it would be equivalent to a 15 course high fence with only one bond beam at the center with an applied wind load of 100 m/h (161 km/h), see Figure 4. Using the current UBC design methodology the fence would be only 6 courses high.

Nine Panel Bind Beam

The specimen achieved an ultimate moment of 3,113 ft-lbs (4222 N-m). This would be equivalent to a 10 course high fence with only one bond beam at the center with an applied wind load of 100 m/h (161 km/h).

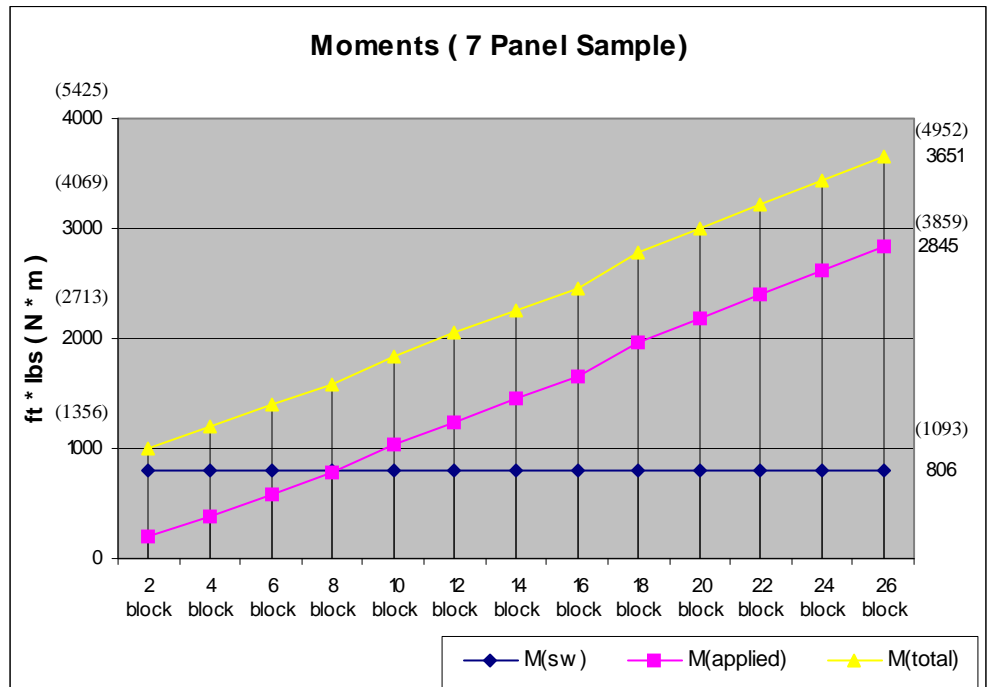

Figure 3: Applied Moment

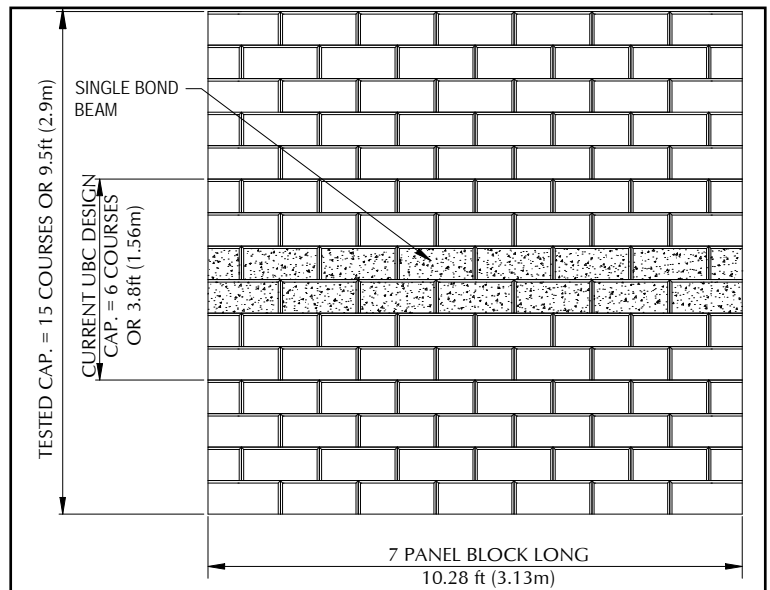

Figure 4: Tested Capacity vs. Current UBC Design

Ultimate Tested Mom. Cap. in the Bond Beam = 3651 ft-lbs (505 kg/m)
Equivalent Wind Load = 19.2 lbs/ft (919Pa)